

Ch 3 - The Building Frame

The building frame for the boat is the cornerstone on which the eventual quality of the boat will rest. The more accurate the construction, the easier that planking the boat will be, so it is well worth taking the time to get this right before rushing on to the "more exciting" parts of building the boat.

You will need:

Dressed Pine

Rails 2 off 45mm x 95mm x 4.8m (preferably slightly longer)

Cross Beams 4 off 45mm x 95mm x 1.22m

Legs 8 off 45mm x 95mm x 500mm

For mounting the moulds, you will also require:

Spalls 5 off 45mm x 45mm x 1.4m

Fixings:

8 off 90° angle brackets

½ kg 25mm screws

¼ kg 80mm screws

When buying the rails, it is worth going to the timber merchants to choose the straightest pair that you can find. The straighter they are the easier aligning the rails will be.

Lay out the rails and the cross beams. The first cross beam becomes the datum for the location of the moulds, and it must be secured at 90° to the rails, with its top dead level to the tops of the rails.

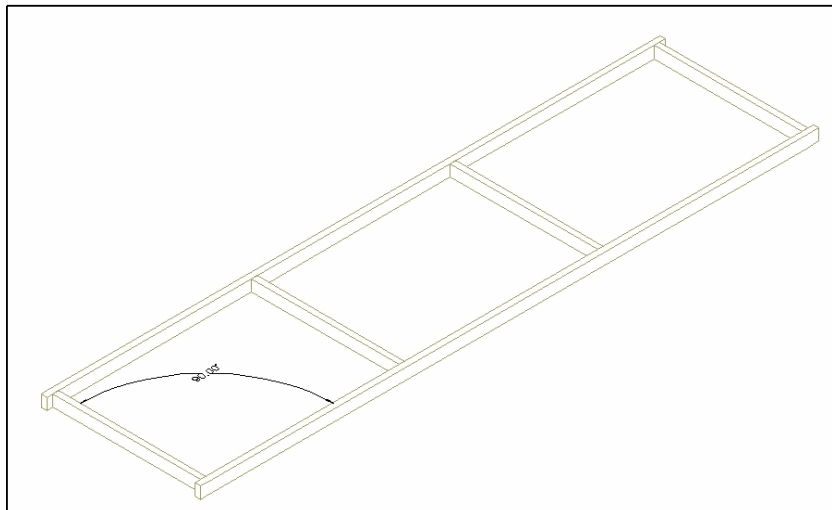

The other crossbeams do not need to be secured as accurately. Screw them together with the angle brackets. Once these are reasonably secure, lift this ladder assembly and clamp the legs in place next to the cross beams - you will

need to be able to adjust the height in order to level the top of the building frame.

Make sure that the whole assembly is in the location in the workshop where you will be building the boat. You need an absolute minimum of 1.2m forward of the bow cross beam, and 6m from there towards the stern. Life will be easier if you have more. You need an absolute minimum of 2ft clear alongside the rails to the wall or other obstructions. Again, the more room you have, the easier the building process will be. If space is not restricted, keep the frame no more than 3' from

the wall, and maximise space on the other side (this assumes that you are not working in a huge warehouse).

Levelling the frame.

As mentioned earlier, it is essential to get the frame as level as possible. You should be aiming for a tolerance over the frame of no more than $\pm 3\text{mm}$. There are two main methods of achieving this.

1. Laser level

Laser levels can be obtained very cheaply, and we recommend this method if you can lay hands on one.

Set up the laser at a spot where it can cover the whole of the building frame, and is not likely to get knocked over. You will need to carry out the whole process without moving the level - if you do, you will need to start again from scratch.

Set the height of the laser level a couple of inches above the top of the building frame, and ensure that it is turning freely and that the bubble does not move at all while being swung through 360° .

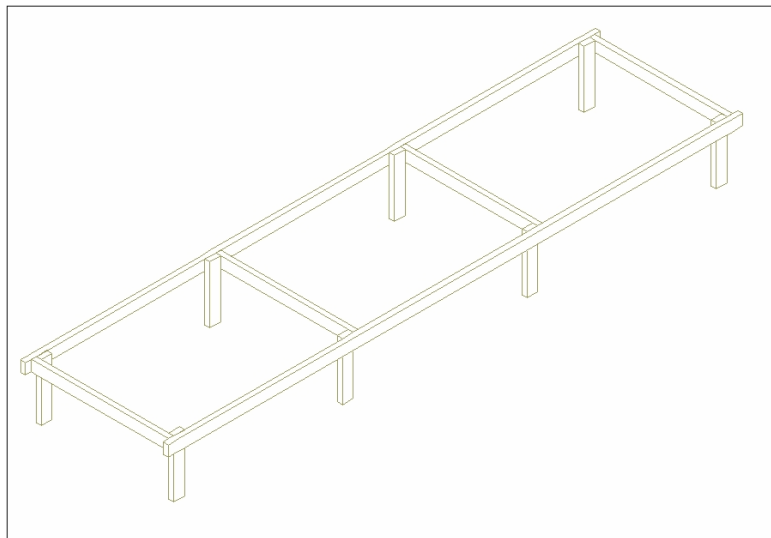

Place a ruler vertically above one of the legs at the datum end, and shine the laser at it to find the height above the frame. This then becomes your datum height. Swing the laser to the other end of the datum crossbeam, and again check the height. Using the clamp, adjust the height so that the top of the building frame is levelled with the datum.

Once the datum end has been set, you then need to work up and down the rails on either side, adjusting the legs as needed until the frame is as flat as you can possibly get it.

Irregularities are best left a little high, as these can then be planed down to level.

Once you are happy that the building frame is level, secure the legs to the rails and cross beams with the 80mm screws, then do one last check around with the laser level to make sure that it is still within the tolerances.

2. Water Tube

Use a clear plastic tube approximately 7m long. The larger the bore of the tube, the quicker the process. The ideal bore is probably around 5mm.

Set up the ladder structure, and clamp the legs to the ladder so that it is roughly level.

Choose a Datum corner, and screw the leg to the ladder. Fix the tube to this corner, and hold the other end above the top of the frame at the same place. Pour in enough water to fill the tube sufficiently that the water level is level with top of the frame. Make sure that there are no bubbles in the tube.

In the same way as the laser levelling, work around the building frame adjusting the height such that the water level is the same in each location.

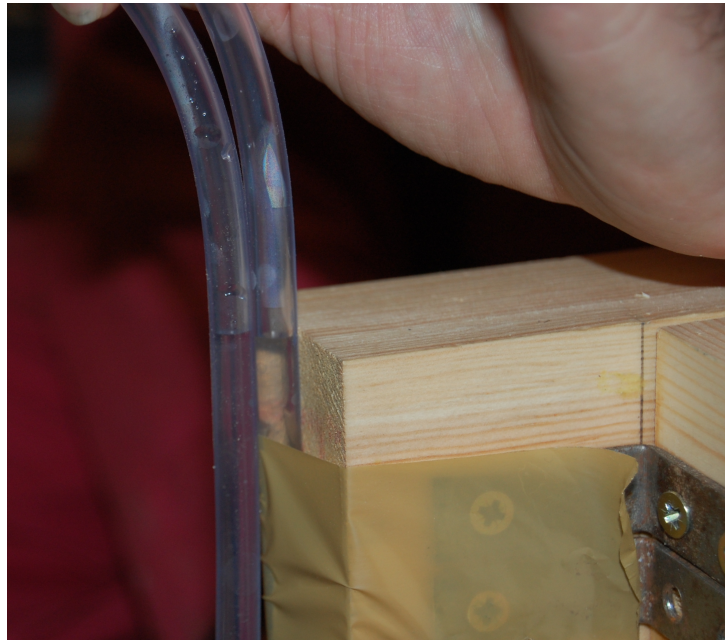

This process is more time-consuming than using a laser level.

Use chalk or spray paint to mark on the floor where the building frame has been set up, in case anyone decides to move it before there is a lot of weight on it. Even better is to bolt the building frame to the floor so that it cannot be accidentally moved.

The last task is to add diagonal bracing (from strips from mould sheet scrap) to make the frame absolutely secure.

Make sure that the diagonal bracing is not going to interfere with the moulds, and that it still allows access to crawl underneath the building frame. This is needed later on in the build, and when lifting the boat off the moulds.